

PERFORMER® SERIES

AERIAL PERFORMANCE HOIST SYSTEM



Maximize Safety While Flying Performers

The Performer® Aerial Performance Hoist provides the kind of safety features on which J.R. Clancy built its reputation, reducing risk to the performer – and to the venue.

Built for Demanding Applications

The Performer hoist is built for portability, or to be moved at the discretion of the director. Its servo motor drive delivers high dynamic capabilities in a small package. Our limit switches can be set without the use of tools, making your setup smooth and efficient. The durable construction and finish can handle the demands of life on the road, and is designed for use in accordance with ANSI E1.43-2016 Performer Flying Systems.

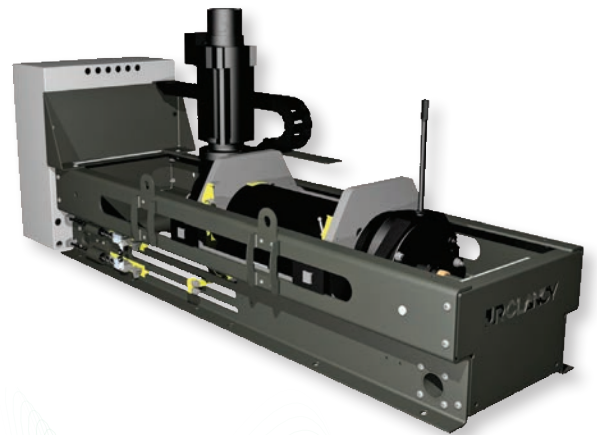

Built for Safety

- Dynamic load measurement detects any over-load or underload situation and rapidly, but safely, stops motion.
- Constant comparison between redundant encoders provides additional safety monitoring and fault response.
- Crossed groove detectors sense the operating conditions, allowing the controller to respond quickly.
- Redundant brakes and structural features capture the load even in the event of a component failure.

Features and Specifications:

- Up to 600 lb* (272 kg) dynamic working load
- Speed of 480 fpm or 680 fpm
- 100' (30.5 m) drum capacity
- 1/4" (6.3 mm) rope diameter
- Moving drum design for constant fleet angle at sheaves
- Dual rope terminations for closed loop operation
- Integral servo drive cabinet
- Cable pinch roller
- Rope can reeve from top or bottom of hoist

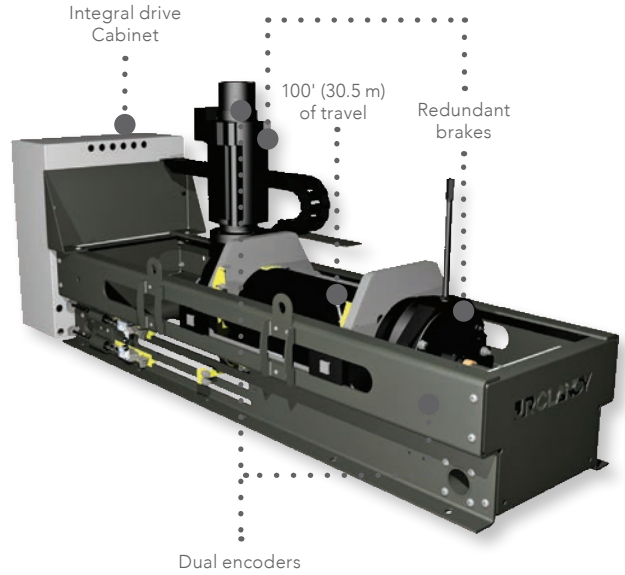

Order Information

NUMBER	DESCRIPTION
018-1855A	Performer® Aerial Hoist 600 lb*, 480 fpm (272 kg, 0-2.4 m/s)
018-1855B	Performer® Aerial Hoist 330 lb*, 680 fpm (136 kg, 0-3.5 m/s)

*Capacity shown is characteristic load as defined in ANSI E1.43 - 2016 Performer Flying Systems.